

Regulatory Information Report

RPF23111

**Fire resistance test for an air duct passing
through a horizontal separating element –
Internal fire**

Issued to: Firestop Centre Ltd

Test method: AS1530.4-2014

Report Date: 12/07/2024

Valid till: 09/08/2028

Test number: PF23111



Table of Contents



- 1.1 Document revision schedule 3
- 1.2 Signatories 3
- 2. Report Summary..... 4
- 3. General Information 5
 - 3.1 Testing Scope 5
 - 3.2 Contact Details..... 5
 - 3.3 Timeline 6
 - 3.4 Use of the Report 6
- 4. Specimen Description..... 7
 - 4.1 Supporting Construction..... 7
 - 4.2 Specimen 1 - Duct..... 7
- 5. Additional temperature measurements 11
- 6. Permissible variations to the tested specimen 12



1.1 Document revision schedule

Revision #	Date	Description
1	25/01/2024	Initial issue for Client review
2	30/01/2024	Issued with Client comments
3	30/06/2024	Typos corrected
4	12/07/2024	Fig. 1b amended

1.2 Signatories

Report	Name	Signature	Date
Prepared by:	Alex Kokorin		12/07/2024
Authorised by:	Andrew Bain (Authorized signatory)		12/07/2024



All tests reported herein
have been performed in
accordance with the
laboratory's scope of
accreditation

2. Report Summary

A 300mm diameter circular air duct was installed vertically, penetrating through a composite concrete slab with profiled decking - 60mm trapezoidal profile and 60mm thick topping. The slab aperture was protected using a combination of slotted steel angle brackets, ceramic fibre, FR board, duct wrap and acrylic sealant. The duct was protected using 25mm thick FIRESTOP Duct Wrap-25, fixed using steel cable ties.

Test results

Structural adequacy	No Failure at 123 minutes
Integrity	No Failure at 123 minutes
Insulation	22 minutes
Fire resistance level (FRL)	120/120/15

The conditions of the test complied with AS1530.4-2014 requirements.

There were no major observations related to the performance criteria during the test.

3. General Information

3.1 Testing Scope

Applicable Standards:

AS 1530.4-2014 Section 9 Air ducts – Internal fire

AS 1530.4-2014 Section 10 Service penetrations and control joints

Departures from Testing Method:

No departures from the testing method

Conditions of the test complied with AS1530.4-2014 requirements.

3.2 Contact Details

Accredited Testing Laboratory

Fire TS Lab - Passive Fire Inspection and Test Services Ltd

Accreditation Number - 1335

1/113 Pavilion Drive, Mangere, Auckland, 2022

New Zealand

Contact e-mail: tests@firelab.co.nz

Issued to:

Firestop Centre Ltd

657 Great South Rd, Penrose, Auckland, 1061

New Zealand

Contact e-mail: info@firestopcentre.co.nz

3.3 Timeline

Testing date:

22/12/2023

Installation completion date:

21/12/2023

Termination of The Test:

The test was discontinued at 123 minutes.

3.4 Use of the Report

Regulatory information report was issued in addition to full test report PF23111. This provides the minimum information required for regulatory compliance.

The report is valid till 09/08/2028.

This report shall not be reproduced, except in full.

This report details the methods of construction, test conditions and the results obtained when the specific element of construction described herein was tested following the procedure outlined in AS 1530.4. Any significant variation with respect to size, constructional details, loads, stresses, edge or end conditions, other than that allowed under the field of direct application in the relevant test method, is not covered by this report.

Because of the nature of fire resistance testing and the consequent difficulty in quantifying the uncertainty of measurement of fire resistance, it is not possible to provide a stated degree of accuracy of the result.

The test results relate to the specimens of the product in the form in which they were tested. Differences in the composition or thickness of the product may significantly affect the performance during the test and may therefore invalidate the test results. Care should be taken to ensure that any product, which is supplied or used, is fully represented by the specimens, which were tested.

The specimens were supplied by the sponsor and the Laboratory was not involved in any of selection or sampling procedures.

The results of these fire tests may be used to directly assess fire hazard, but it should be recognized that a single test method will not provide a full assessment of fire hazard under all fire conditions.

4. Specimen Description

4.1 Supporting Construction

Separating element		
1.1	Item	120mm Composite slab with profiled decking Width/Length: 1455mm x 1225mm
	Aperture	350mm diameter 25mm (nominal) annular gap around duct
	Dimensions	Floor Thickness (T): 120mm
		Trapezoidal depth: 60mm
Concrete topping depth: 60mm		
	Profile pitch: 300mm	

4.2 Specimen 1 - Duct

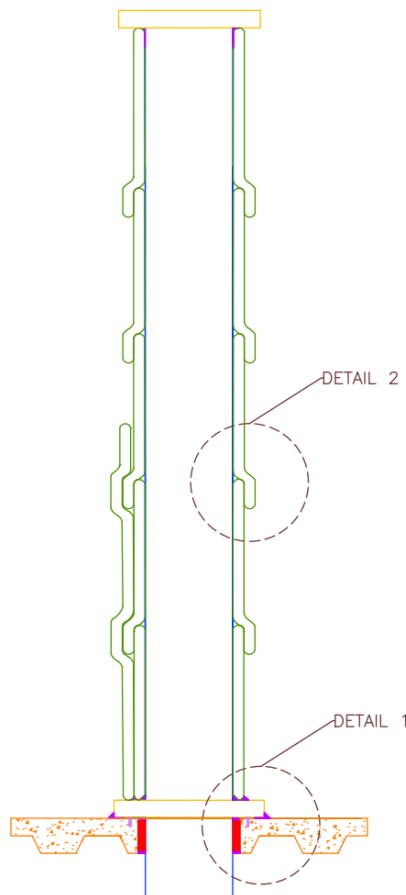

Figure 1 – Duct cross section

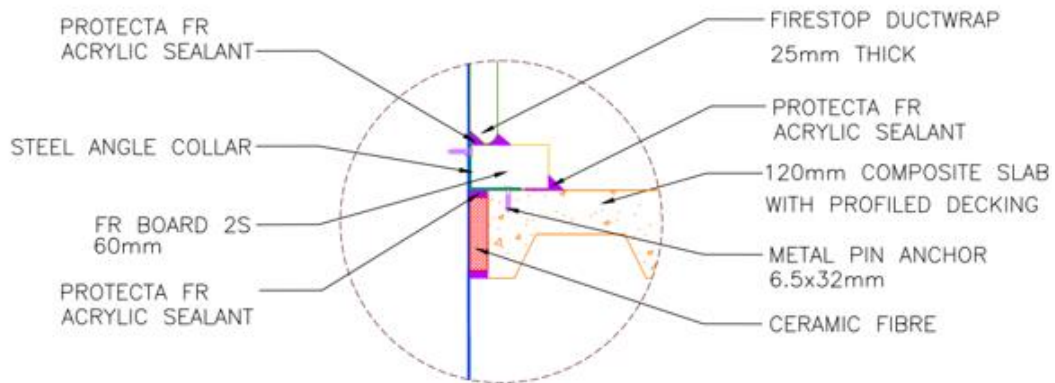

Figure 1a – Detail 1

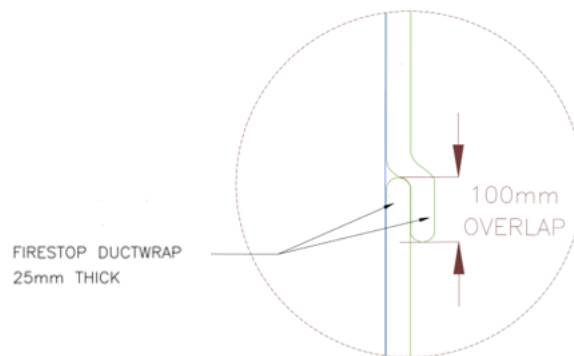

Figure 1b – Detail 2

Specimen		
2.1	Item	Air Duct (as per AS4254.2)
	Measurements	Diameter / Thickness (D/T): 300mm x 0.67mm
	Specimen Support	Unistrut structure at 1970mm
	Aperture Size	350mm
	Annular Spacing	25mm
	Installation	Asymmetrical – Protrudes 270mm from exposed face, 2650mm from unexposed face. The annular gap between the horizontal separating element and the duct was filled with ceramic fibre wrap content – recessed 20mm for sealant application. The gap was filled with 20mm deep Protecta Acrylic sealant. Slotted steel angles were installed from the top around the duct flush with the separating element and fixed to the duct and the slab. FR Board collar was installed on the top of the

		<p>steel angles and fixed to the slab. All joints were sealed with bead of Acrylic sealant.</p> <p>One layer of the duct wrap was installed around the duct having nominal 100mm overlap for the longitudinal and transverse joints. Longitudinal joints were staggered and located minimum 200mm from the edge of the duct.</p> <p>An extra layer of wrap (W/H: 300mm x 600mm) was fixed by Steel ties and Firestop Foil Tape.</p> <p>The duct was tested open on the fire side.</p>
--	--	---

Wrap		
3.1	Item	FIRESTOP Duct Wrap-25 – foil faced ceramic fibre blanket
	Measurements	Thickness / Width / Length (T/W/L): 25mm x 600mm x 5000mm
	Density	96 kg/m ³
	Installation	<p>Used to wrap the Air duct on unexposed face.</p> <p>First length was butting up against the board, second and subsequent layers overlapping the previous by approximately 100mm.</p> <p>An additional section of wrap was trimmed to 300mm wide and was butt joined to FR Board, extending 1200mm towards the open end.</p>
3.2	Item	FIRESTOP Duct Wrap-25 –ceramic fibre blanket (foil face removed)
	Measurements	Thickness / Width / Length (T/W/L): 25mm x 600mm x 5000mm
	Density	96 kg/m ³
	Installation	Installed into annular gap between duct and separating element. Ceramic wrap was recessed 20mm from both faces of the separating element.

Board

4.1	Item	Protecta FR Board 2S
	Measurements	Length / Width (L/W): 1200mm x 600mm
	Thickness	Thickness (T): 60mm
	Installation	The Board was trimmed to a 550mm x 550mm square. The Board was installed around the duct on the unexposed face of the separating element.

Sealants / Backing		
5.1	Item	Protecta FR Acrylic Sealant
	Measurements	310mL tube
	Installation	Installed in annular gap between separating element and duct. Installed to FR Board joints, separating element and FR Board joints, FR Board and duct joints, FR Board and wrap joints.

Fixings		
6.1	Item	Plain Aluminium Foil Tape
	Measurements	Width: 75mm, Thickness: 50 microns
	Installation	Used to seal all cut ends of duct. Used to join additional 300mm layer of duct wrap to the duct.
6.2	Item	Metal Pin Anchor
	Measurements	6.5mm x 32mm
	Installation	Used to fix the slotted steel angle to duct at 100mm centres
6.3	Item	Slotted Steel Angle
	Measurements	Width / Height / Thickness: 70mm x 70mm x 0.8mm
	Installation	Used to fix the duct to the separating element. Steel between each slot was cut, then angle was wrapped around and fixed to duct.
6.4	Item	Stainless Steel Cable Tie
	Measurements	Width / Length(W/L): 12mm x 1000mm
	Installation	Used to fix 1 st layer of duct wraps to the duct.

5. Additional temperature measurements

Additional thermocouples were installed to assess the performance of the duct wrap protection at different distances from the floor.

Layers of wrap	From the board, mm	Maximum temperature rise, deg C			
		30 min	60 min	90 min	120 min
1	25	135	284	334	351
	400	227	308	337	361
	550	166	233	247	259
	950	189	272	306	317
	1050	122	190	206	213
	1650	98	159	191	205
	1900	104	172	192	202
2	50	109	210	242	268
	400	93	191	216	235
	650	68	173	193	211
	925	61	153	175	189

6. Permissible variations to the tested specimen

A test result obtained for the largest air duct in the range may be applied to all air ducts of the same type (including any aspect ratio), provided the maximum dimensions do not exceed those tested and that the components remain in the same orientation as that tested.